

ZEN
PRO
USER MANUAL

v1.0



smartsystem

MADE IN ITALY

General Index

1	Safety.....	3
2	Packing List.....	4
3	Specs.....	4
4	SmartCAM Zen PRO Overview.....	5
5	Register the product on SmartSystem Care Platform.....	5
6	XTBus connection.....	5
7	Mounting Zen PRO on your sled.....	6
8	Powering Zen PRO.....	8
9	Turning on Zen PRO.....	8
10	Booting process.....	9
11	Interaction with Zen PRO.....	9
12	Status LED.....	10
13	Zero Offset Setup and Offset LED behavior.....	10
14	Balance LED.....	11
15	Power consumption.....	11
16	Firmware Upgrade.....	12
17	Maintenance.....	12
18	Disposal.....	12
19	Warranty.....	13



This manual refers to the following firmware revision:

- v 1.0.7.3

In case your product has a different version, upgrade it via Burner as reported in Par.16

1 Safety

SmartCAM Zen PRO has been designed considering all the technical regulations concerning the product.

Please, carefully read the safety instructions and retain for future reference.

- Protect your equipment from heavy dust environments.
- Avoid, if possible, any contact with water or other liquids
- Clean only with a dry cloth or lightly soaked in distilled water.
- Do not use a power supply different from the one provided with the product, if provided
- In case of failure, the Zen PRO must be repaired only by qualified staff, authorized by SmartSystem Srl.
- Do not remove any part or disassembly the SmartCAM Zen PRO. There are no reusable parts in the SmartCAM Zen PRO
- Due to the constant effort of product improving, SmartSystem reserve the right to make changes and improvement to the product described in this manual

WARNING



To prevent fire, explosion or electrical shock, **NEVER USE the product under heavy rain or partially or totally submerged**

TO AVOID ELECTRICAL SHOCK, DO NOT OPEN THE PRODUCT FOR ANY REASON. ALWAYS REFER TO QUALIFIED STAFF AUTHORIZED BY SMARTSYSTEM SRL.



The user has been informed about the importance of reading and understanding the safety instructions contained in this manual.



The Zen PRO is entirely fanless and features a unique thermal management system that maintains sensors at a consistent temperature. As a result, the case may become warm, which is completely normal.

2 Packing List

- 1x SmartCAM Zen PRO
- 1x XT-Bus cable 40cm / 1.57"
- 1x 5gr Silica bag

3 Specs

- Multi axis Digital Level indicator
- Able to send on XT-BUS simultaneously
 - Roll Axis
 - Tilt Axis
 - Yaw Axis
 - Side to Side acceleration
- Completely milled from solid aluminum case. Shot peened and Hard anodized
- Possibility to zero in every position.
- 1x pole Push-Pull connector as power input
- 2x XTBus Port for quick daisy chain connection
- Power Supply Range : 9VDC to 34VDC
- Max power consumption : up to 7.2W during heating mode / less than 1W in operation mode
- Working Temperature : -20°C ~ +40°C
- Working Environmental Humidity: 10% ~ 80%
- Weight : 120grams / .26lbs



**IN THE CASE OF MALFUNCTION OF THE Zen PRO,
CONTACT AN AUTHORIZED SMARTSYSTEM TECHNICIAN.
DO NOT OPEN YOUR Zen PRO IN ORDER TO MAKE QUICK
AND MAKESHIFT REPAIR.**

4 SmartCAM Zen PRO Overview

Reference	Description
A	Main Button
B	Status LED
C	Offset LED
D	Balance LED
E	Clamp Knob
F	XTBus ports in daisy chain configuration
G	2Pin Power input
H	15mm rods mini clamp

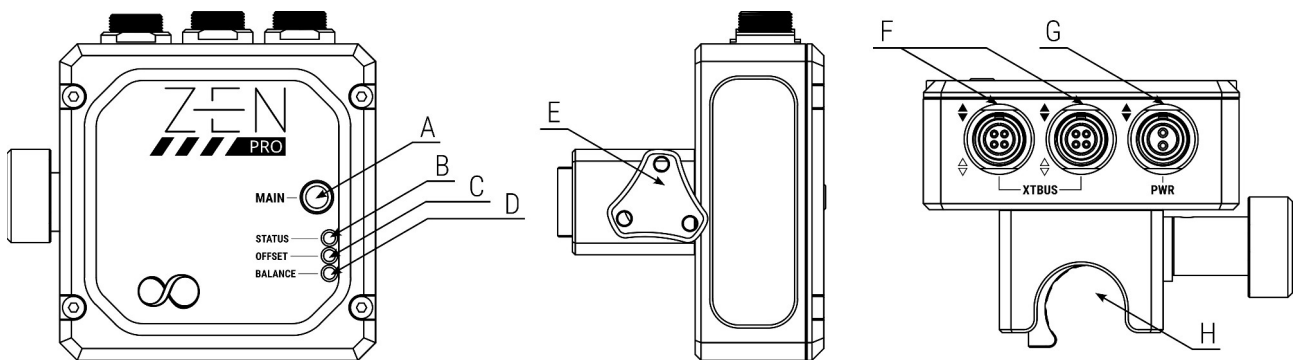

5 Register the product on SmartSystem Care Platform

It is highly suggested, if not mandatory, to register the product on the SmartSystem Customer Care portal reachable at the following LINK : <https://care.smartsystem.com>

After the registration, the portal will automatically inform you via email, once new firmware updates will be available offering an improved experience with your new Zen PRO.

NOTE : It is suggested to browse the link above via a PC or Mac browser avoiding mobile devices.

6 XTBus connection

The Zen PRO is among the first devices to comply with XTBus standards. Since XTBus transmits both data and power to connected devices, it is strongly recommended to adhere to the following guidelines when interconnecting devices:

1. Connect all devices using XTBus cables.
2. Only connect the first unit in the chain to the power supply after completing the XTBus interconnection.

7 Mounting Zen PRO on your sled

The Zen PRO is equipped with an automatic orientation detection system that enables it to reconfigure the sensor for optimal performance. This feature ensures accurate indication of roll, tilt, and side-to-side acceleration.

The Zen PRO can be natively mounted on 15mm rods in the following configurations.

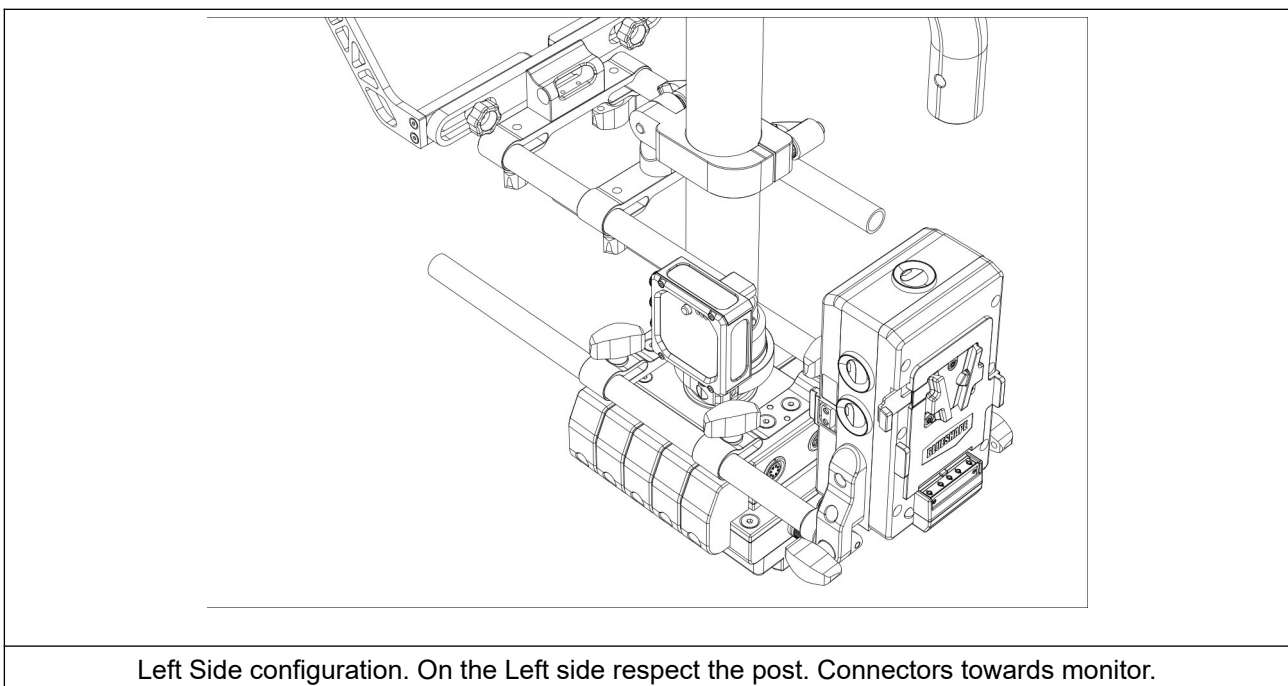
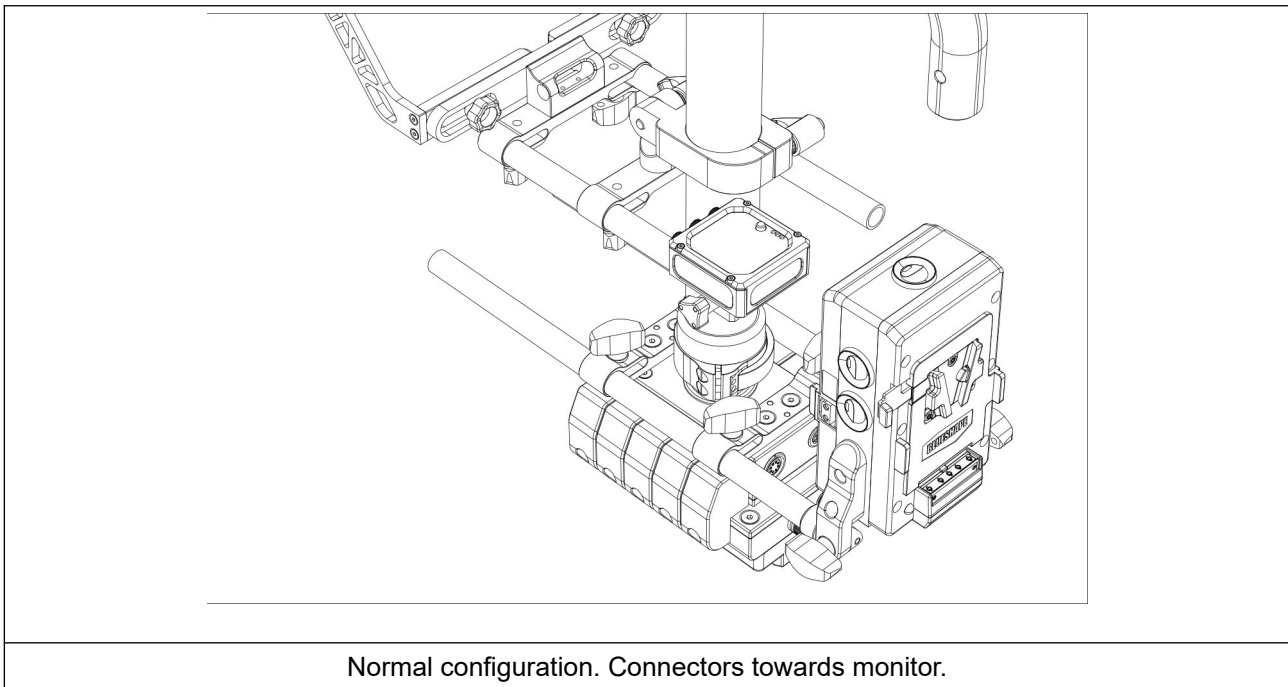

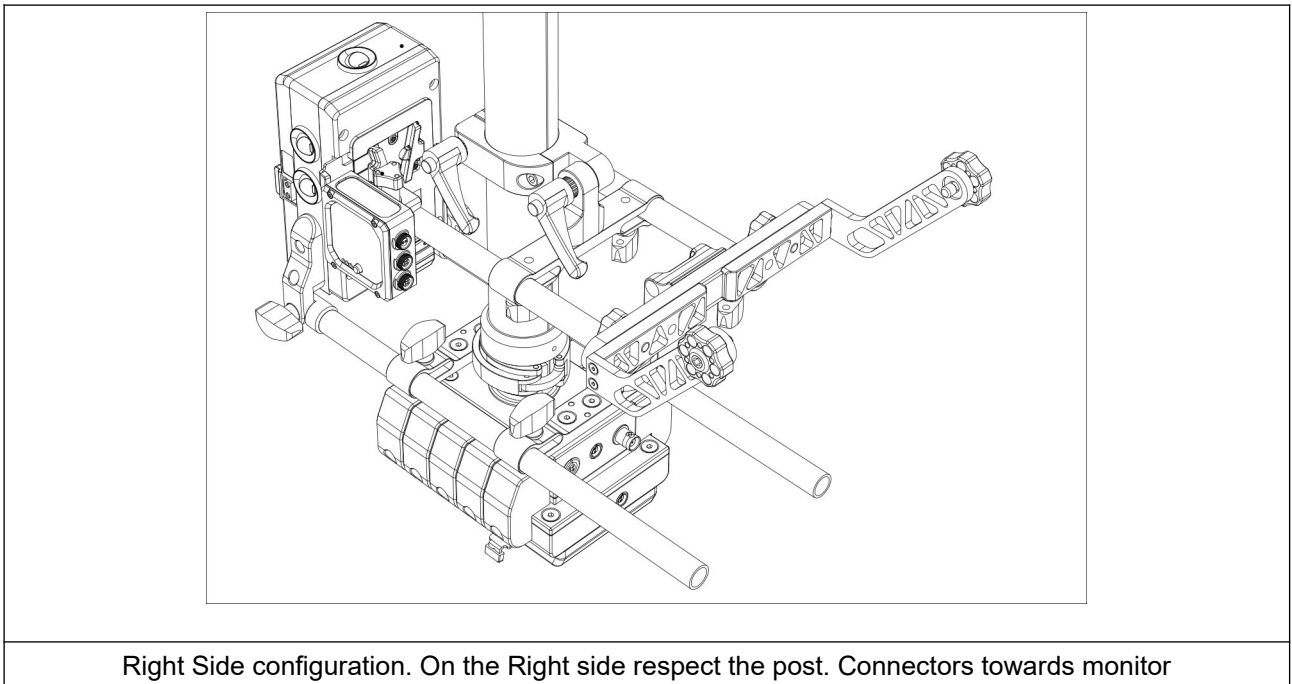
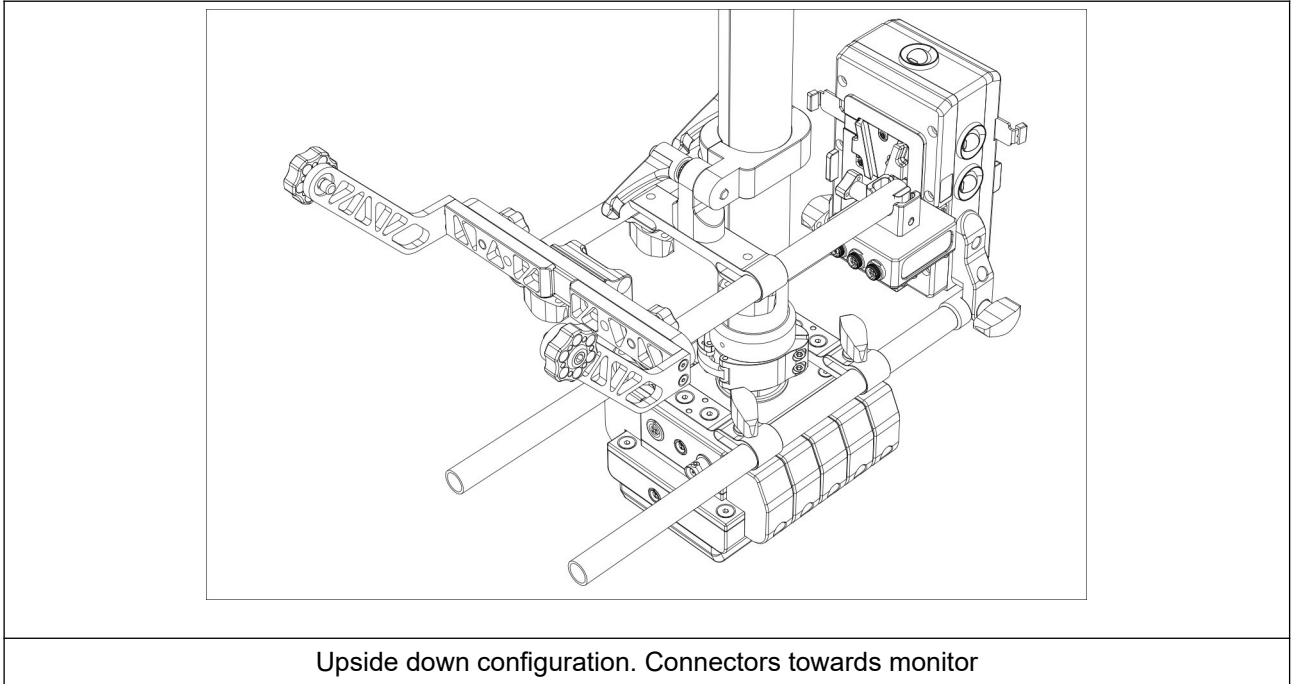

The above representations serve only as a reference. Users can mount the Zen PRO wherever they prefer, regardless of whether the rods are used for the monitor or the battery pack.

It is important to keep the Zen PRO as aligned as possible once an orientation is chosen. Minor misalignments of up to $\pm 10^\circ$ are compensated for by the internal algorithm.

The mini clamp of the Zen PRO attachment is designed to seamlessly work on ground carbon fiber with a 15mm diameter.

Note: With a custom attachment, the Zen PRO can also be mounted directly at the rear of your sled's post, aligned with the post with the connectors facing either up or down. For more information, please contact the SmartSystem technical department.

8 Powering Zen PRO

The input stage electronics of Zen PRO is able to accept a wide range of voltages ranging from 9VDC up to 34VDC and protect the monitor from

- Over voltage (over 34VDC)
- Under voltage (under 9VDC)
- Reverse polarity

The input connector (Par.4 Ref.G) is a standard 2 pin connector compatible with LEMO® 0B.302 connector.

The pinout follow the ARRI® standard where the negative is connected to the pin toward the (Red Reference) of the connector.

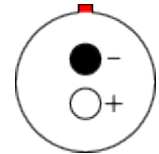

In the event of a fault, the system will automatically shut down, and no LEDs will be illuminated. If this occurs, disconnect the power cable from the first XTBus device in the chain, along with all XTBus cables. Then, systematically diagnose the issue to identify which device is causing the problem.

9 Turning on Zen PRO

The Zen PRO can serve as the initial power distributor for the entire XTBus network or be powered by the XTBus network, depending on the configuration used.

Since the Zen PRO can only transmit its data to an XTBus-compatible monitor, such as the SM7 PRO 3G, it is typically the first unit in the XTBus network receiving a direct power connection from your Sled and serving other appliances via XTBus.

In both scenarios, the Zen PRO automatically powers on when voltage is supplied to the power input, enabling the system to quickly perform diagnostic procedures (Refer to Par. 10) and achieve stable performance swiftly.

During startup, its innovative heating system evaluates the environmental temperature and works to stabilize the internal temperature for the sensors as rapidly as possible (Refer to Par. 15).

10 Booting process

Immediately after the Zen PRO is powered on, the device initiates the booting process. During this phase, all peripherals are checked and initialized, providing the user with visual feedback.

During this period, the device is totally unresponsive.

The initialization process consists of two steps. Each LED on the Zen PRO corresponds to a specific device, as outlined in the following table:

LED	Peripheral
Status	XTBus
Offset	Sensor #1
Balance	Sensor #2

In the first step, the peripherals are initialized. If the initialization process is successful, the corresponding LED will light up **white**.

The second step involves configuring each peripheral. If the configuration process completes successfully, the corresponding LED will light up **green**. If there is an error, the LED will turn **red**.



In the event of an error, whether during the booting process or regular operation, all LEDs will blink. **This simultaneously blinking pattern occurs exclusively during an error status.** The specific device experiencing the error will be indicated by a **RED blinking LED**. If an error occurs, please contact a SmartSystem technician and provide the product's serial number and details about which LEDs are blinking to facilitate a prompt diagnosis of the issue.

Once the check process is complete, the product will automatically pass in **operational mode** shown to the user with the Main Status LED colored in Solid BLUE or in Blinking RED as reported in the following paragraph.

11 Interaction with Zen PRO

The main button is the sole means of interacting with the Zen PRO. Its use is extremely simple and straightforward, as demonstrated in the tables below, subdivided by short and long press.

Short press	Mode	Result
1 click	Normal	No operation related
2 clicks	Normal	Enable/Disable the zero offset, if present
3 clicks	Normal	Enable/Disable the XTBus communication
4 clicks	Calibration	Start/Stop the procedure for the sensors' absolute offset
5 clicks	Calibration	Activate/Deactivate the procedure for the sensors' internal calibration

Long press	Result
If Normal Mode	Starts the zero offset procedure
If Calibration Mode	Save persistently the result in the internal memory







Note: Clicking the main button 4 or 5 times puts the Zen PRO **into calibration mode**. If the user inadvertently enters this mode, simply press the main button the same number of times to exit. In case of panic, unplug the power. Incorrectly adjusting these settings may lead to improper behavior of the Zen PRO in the field. Adjustments can be easily corrected at home on a stable, flat surface that is as parallel to the ground as possible.

At the same time, it is important to allow the user to access and utilize these settings when necessary, especially in cases where the Zen PRO produces uncalibrated results, so that recalibration can be performed without sending the device back to SmartSystem.

The Calibration process is not included in this user manual.

12 Status LED

The main status LED, since RGB type, can inform the user of the current status of the whole system as reported below:

Color	Appearance	Mode	Description
 Blue	Solid	Normal	Normal Operation
 Red	Blinking	Normal	XTBus communication error
 Purple	Solid	Calibration	Sensors in internal calibration mode
 White	Solid	Calibration	Sensors in absolute offset calibration mode

Note: Sensors in calibration mode are intended for internal use or should be engaged only once fully understood how to operate them (See Par.11)

13 Zero Offset Setup and Offset LED behavior

The Zen PRO allows users to zero it at any angle when mounted in the positions outlined in Paragraph 8 within an angular offset of max +/- 10°.

To zero the device, simply press and hold the main button for at least two seconds.



Once the zeroing process is initiated, the Zen PRO will indicate this with an Amber blinking pattern on the Offset LED.

After the system stabilizes, and following a five-second period, the new zero setting will be recorded, and the Offset LED will light up solid Green.

The user can remove the zero offset and later reset it by double-clicking the main button.

The zero offset is not permanent and needs to be redefined each time the device is restarted.

Below a simple and quick recap of the Offset LED appearance

Offset LED	Appearance	Description
 Green	Solid	Zero Offset active and recorded
 Red	Blinking	Zero Offset procedure initiated
	Off	No Zero applied to the output

And the action related to the main button for zeroing process

Interaction with Main Button	Result
Keeping pressed for at least 2 seconds	Starts the zeroing process
Two consecutive clicks	Enable/Disable the zero offset, if present



Note: The zeroing process can only be initiated if the system is in normal condition, indicated by the status LED being solid blue.

14 Balance LED

In Normal mode (Par. 12), the Balance LED indicates the temperature status of both sensors inside the Zen PRO.

The Zen PRO is the first digital level indicator that provides its sensors with a controlled temperature environment, essential for ensuring reading stability and optimal performance.

The user receives straightforward visual feedback about the overall status of the sensors as follows:

Balance LED	Appearance	Description
 Green	Solid	Terminal temperature reached and controlled with active feedback
 Green	Blinking	Approaching the Terminal temperature. Controlling the ramp.
 Red	Solid	System cold. Heater engaged. Full power requested

15 Power consumption

As described in Par. 14, the Zen PRO is capable of generating and regulating the temperature around the MEMS sensors to create an optimal environment for them.

To achieve this state as quickly as possible, a heater is utilized and then controlled.

Consequently, the current consumption of the Zen PRO is not constant; it initially peaks at up to 7.2W depending on the external/environmental temperature.

Once the system reaches a stable and controlled state, the power consumption of the Zen PRO drops to less than 1W.

16 Firmware Upgrade

Zen PRO can be upgraded directly by the user using the software BURNER freely downloadable from the SmartSystem website at the following link : <https://www.smartsystem.com/software/>.

Burner software is compatible with XTDevices only from release 3.x onwards.

Since Zen PRO is an XTBus device, is it possible to connect it to a standard PC or Mac via the XTDongle in bundle with the product.

In order to verify and upload a new firmware to your Zen PRO

1. Power on the device with a fully charged battery or with a reliable source with a DC Line with a voltage range between 9VDC and 34VDC without any signal input
2. Connect XTDongle to Zen PRO on the XTPort connector using the 4 pin connector
3. Connect the XTDongle via the USB Type A connector
4. Start Burner software

The system will automatically recognize your product and inform you whether or not it is possible to install a new firmware update for the XTDevice connected.



During the firmware update procedure, never turn off or disconnect the product before Burner completes the firmware upload process.

17 Maintenance

Do not use alcohol or other solvents nor detergents to clean your SmartCAM Zen PRO. To clean metal components, we recommend you to use a paper towel lightly soaked in distilled water. Make sure no water drops reaches the inside components of SmartCAM Zen PRO.

18 Disposal

Dispose of your SmartCAM Zen PRO in accordance with current regulations. Address to special authorities or companies in charge of scrapping metallic materials and waste disposal.

Pursuant to Article 13 of the Italian Legislative Decree no. 151 of 25 July 2005, "Implementation of Directives 2002/95/EC, 2002/96/EC and 2003/108/EC regarding the reduction in use of dangerous substances in electrical and electronic equipment as well as waste disposal".

The user must therefore dispose of the product in question at suitable recycling centers for electronic and electro-technical waste, or he/she must turn the used product over to the retailer when buying a new equivalent product, on a one-to-one basis. Separate waste collection allows used equipment to be recycled, treated and disposed of without negative consequences for the environment and health, and it allows the materials in the equipment to be recycled. Illegal dumping of the product by the user entails application of the administrative sanctions stated in the Italian Legislative Decree No. 22/1997 (Article 50 et seq of the Italian Legislative Decree No. 22/1997).

19 Warranty

SmartSystem Srl headquarter is located in Via del Commercio, 22F, 61032 FANO(PU), ITALY. Smartsystem main brand and all the other brands associated with it are property of SmartSystem Srl.

Your SmartSystem equipment is guaranteed against any manufacturing or material defects for 12 months from the date of delivery to the customer. Warranty will cover any functioning issues related to manufacturing or material faults.

In this case, the company reserves the right to decide whether eliminating the defect or providing the customer with a new product.

Any claims due to manufacturing or materials faults must be communicated by the customer, upon presentation of the warranty card, properly completed, or of a proof of purchase.

The warranty, which will expire after 12 months, will not be extended either by a complaint, or by subsequent executions. Damage caused by accident, misuse, do-it-yourself repairs or modification, repair by unauthorized service center, static charges or mechanical damages is not covered by the warranty.

Furthermore, warranty won't be valid neither in case the warranty card is arbitrarily modified.

Repairs must be made only by authorized service centers.

ALWAYS REQUEST THE RMA NUMBER BEFORE SENDING US THE PRODUCT